

EC800X QuecDuino EVB

EC800X QuecDuino EVB

V1.1

2024-12-25

LX

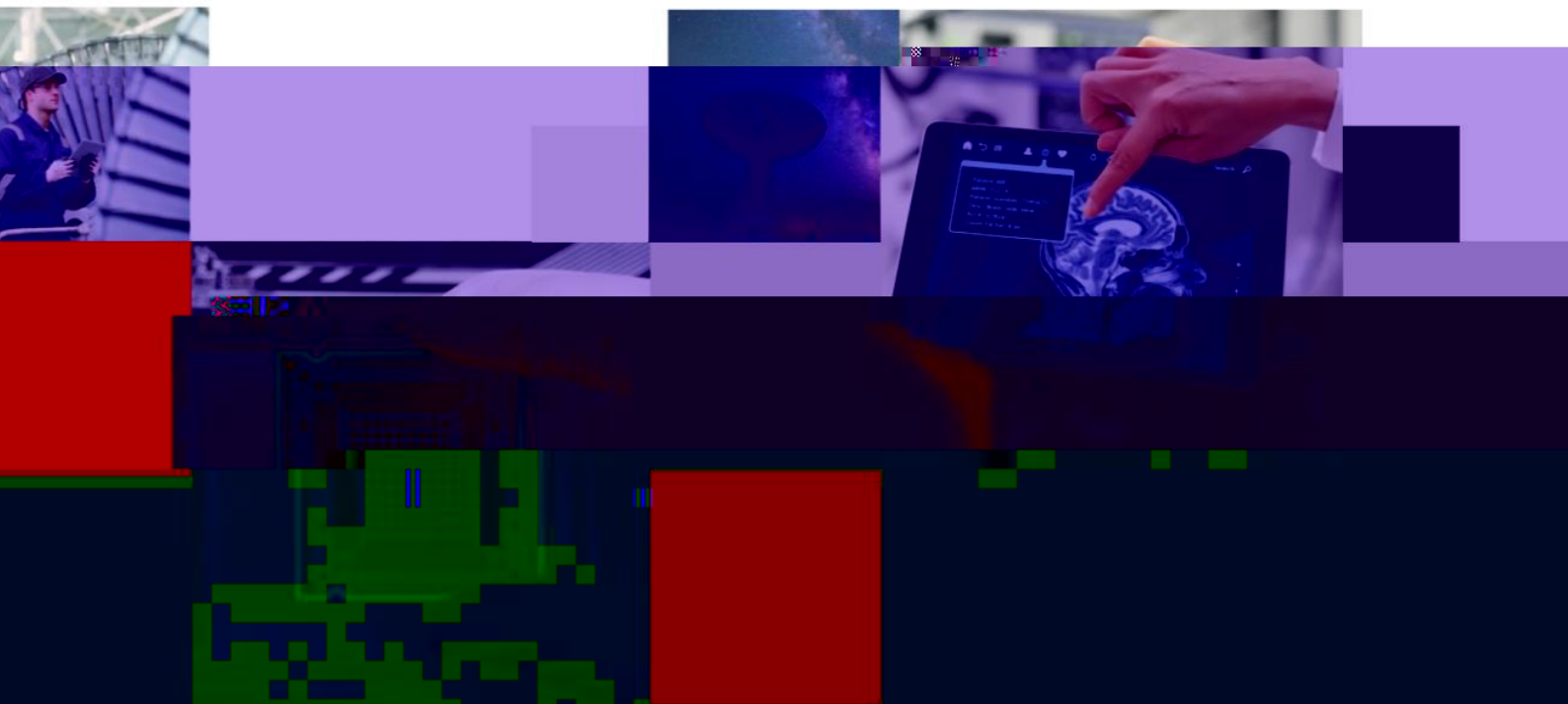

1

EC800X QuecDuino EVB EC800
EC800M EC800K EG800K EC800E

1.1 EC800X QuecDuino EVB

QuecDuino EVB 4G FPC

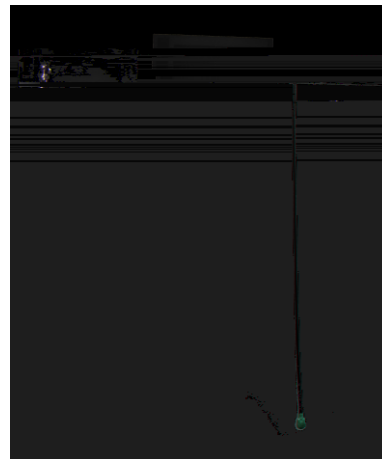
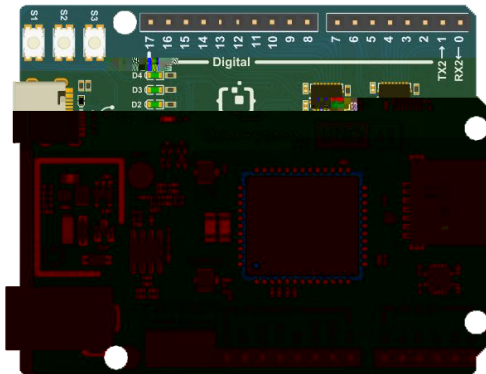

1 EVB

Features

CPU

EC800 / EG800 Module Series

Pins

22x digital pins (GPIO), D0-D3,0-17 up to
2x analog input pins (ADC), A0-A1

Peripherals

Antenna Interface,LTE & GNSS(option)

SIM Interface, NANO SIM

USB 2.0, TypeC

Arduino female header Interface

Audio(option)

1xMIC onboard

1x 3W Class-D Stereo Amplifier

Power

Recommended input voltage (VIN) is 4.5-5.25 V/2A

Power via USB-C® at 5 V

Power via DC05® at 5-16V

3.3V/200mA output

Communication

4x UART (pin 0, 7) up to

1x SPI (pin 10-13, ICSP header)

1x I2C (pin 16, 17, SDA, SCL)

3x KEY(S1-S3)

4x LED(D1-D4)

1x RESET(Pull-down reset Module)

1x BOOT(According to different model modules pull up or Pull-down the BOOT pin, Before power-on)

2

2.1

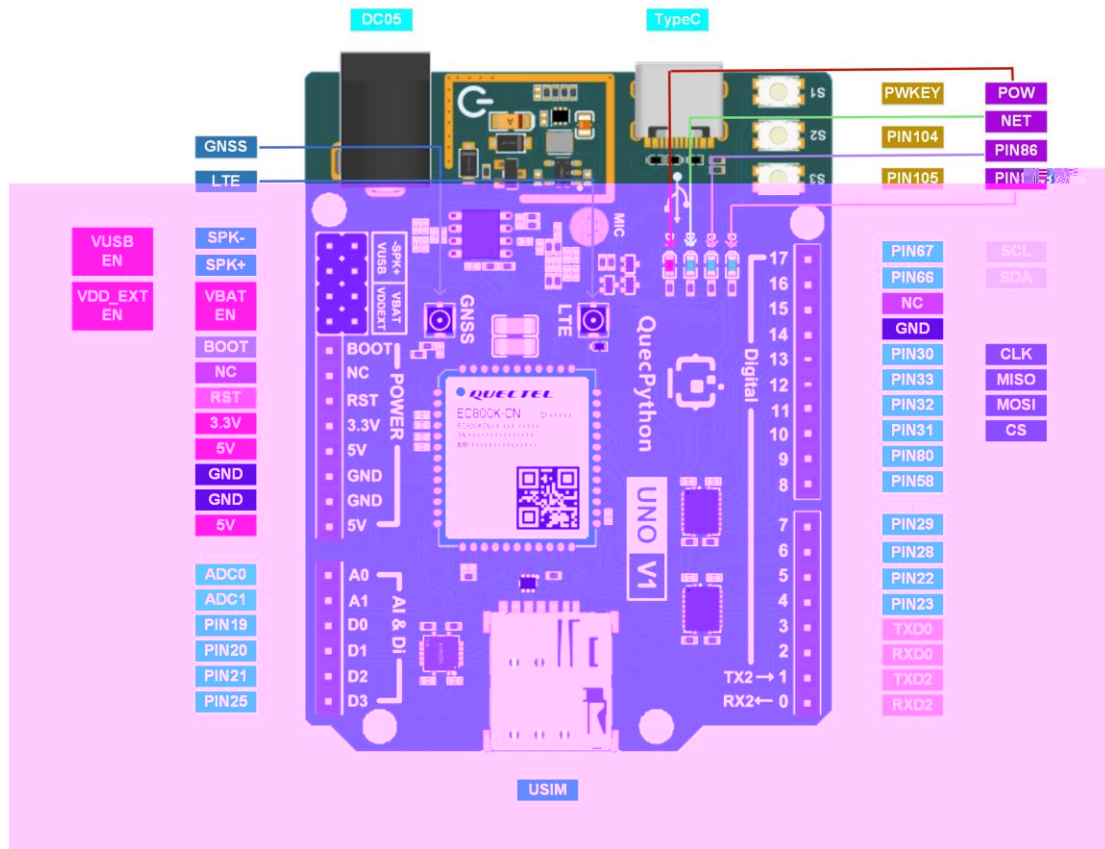

2.2

1

		DC
BOOT	USB_BOOT	
NC		
RST	RESET	

3.3V		3.3V/200mA
5V	/	5V/2A V1.1
GND		
GND		
5V	/	5V/2A V1.1
A0	ADC0	0-1.2 V
A1	ADC1	0-1.2 V
D0	I/O 19	3.3V
D1	I/O 20	3.3V
D2	I/O 21	3.3V
D3	I/O 25	3.3V
0		3.3V
1		3.3V
2		3.3V
3		3.3V
4	I/O 23	3.3V
5	I/O 22	3.3V
6	I/O 28	3.3V
7	I/O 29	3.3V
8	I/O 58	3.3V
9	I/O 80	3.3V
10	I/O 31	3.3V
11	I/O 32	3.3V
12	I/O 33	3.3V
13	I/O 30	3.3V
14		
15	NC	
16	I/O 66	3.3V

BOOT
BOOT

BOOT

BOOT GND

2.3

EVB 4

D1

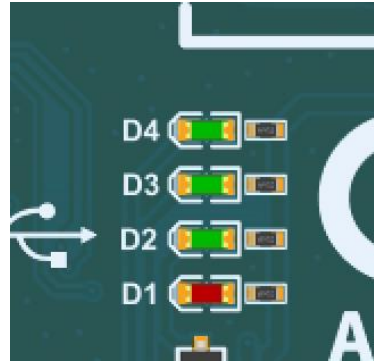

D2

2

	200ms /1800ms	
D2	1800ms /200ms	
	125ms /125ms	

D3 D4

86 87

3 SIM



EVB NANO SIM USIM ETSI IMT-2000
1.8 V 3.0 V USIM

4 USB

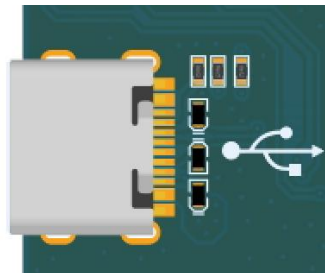

EVB 1 TypeC USB USB USB 2.0
USB 2.0 480 Mbps 12 Mbps
AT GNSS NMEA

5 ADC

EVB 2

ADC

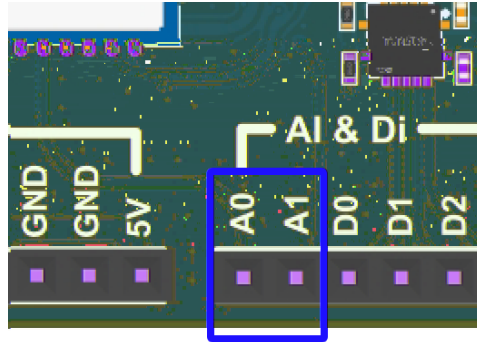

3 ADC

6

6.1

6.1.1

5

引脚名	引脚号	I/O	描述	备注
ANT_MAIN	35	AIO	主天线接口	50 Ω 特性阻抗。

备注

模块支持 Wi-Fi Scan 功能。由于共用主天线接口，两种功能不可同时使用，时分复用，Wi-Fi Scan 只接收不发送。

6

工作频段	发送 (MHz)	接收 (MHz)	备注
~170	LTE-FDD B34	1970~1980	~170
~180	LTE-FDD B38	1710~1735	~180
~194	LTE-FDD B39	1824~1849	~194
~260	LTE-FDD B38	2600~2615	~260
~2025	LTE-TDD B34	2010~2025	2010~
~2620	LTE-TDD B38	2570~2620	2570~
~1920	LTE-TDD B39	1880~1920	1880~
~2400	LTE-TDD B40	2300~2400	2300~
~2675	LTE-TDD B41	2535~2675	2535~

6.1.2

7

频段	最大值	最小值
LTE-FDD B1/B3/B5/B8	23 dBm ±2 dB	< -39 dBm
LTE-TDD B34/B38/B39/B40/B41	23 dBm ±2 dB	< -39 dBm

6.1.3

8

频段	接收灵敏度 (典型值) (dBm)			3GPP 要求 (主集 + 分集)
	主集	分集	主集 + 分集	
LTE-FDD B1 (10 MHz)	-99.5 dBm	-	-	-96.3 dBm
LTE-FDD B3 (10 MHz)	-99.0 dBm	-	-	-93.3 dBm
LTE-FDD B5 (10 MHz)	-98.5 dBm	-	-	-94.3 dBm
LTE-FDD B8 (10 MHz)	-99.0 dBm	-	-	-93.3 dBm
LTE-TDD B34 (10 MHz)	-100.0 dBm	-	-	-96.3 dBm
LTE-TDD B38 (10 MHz)	-99.0 dBm	-	-	-96.3 dBm
LTE-TDD B39 (10 MHz)	-100.0 dBm	-	-	-96.3 dBm
LTE-TDD B40 (10 MHz)	-100.5 dBm	-	-	-96.3 dBm
LTE-TDD B41 (10 MHz)	-99.0 dBm	-	-	-94.3 dBm

6.2 GNSS

- EVB GNSS GNSS
- GPS BDS GLONASS Galileo
- NMEA 0183 NMEA AT USB
- UART 1 Hz
- GNSS AT

6.2.1

9

GPS	1575.42 ±1.023 (L1)	MHz
BDS	1561.098 ±2.046 (B1I)	
Galileo	1575.42 ±2.046 (E1)	
GLONASS	1597.5~1605.8 (L1)	

6.2.2 GNSS

10 GNSS

参数	条件	典型值	单位
灵敏度	捕获	-146	dBm
	重捕	-160	
	追踪	-160	
首次定位时间	冷启动 @ 空旷区域	28	s
	温启动 @ 空旷区域	27	
	热启动 @ 空旷区域	3.7	

备注

1. 追踪灵敏度：模块可以捕获并跟踪导航信号并正常定位所需的最低信号电平。（持续定位至少2分钟）
2. 重捕灵敏度：模块接收的导航信号失锁后3分钟内，重新捕获并正常定位所需的最低信号电平。
3. 捕获灵敏度：模块进行冷启动后3分钟内，捕获导航信号并成功定位所需的最低信号电平。

6.3

EVB

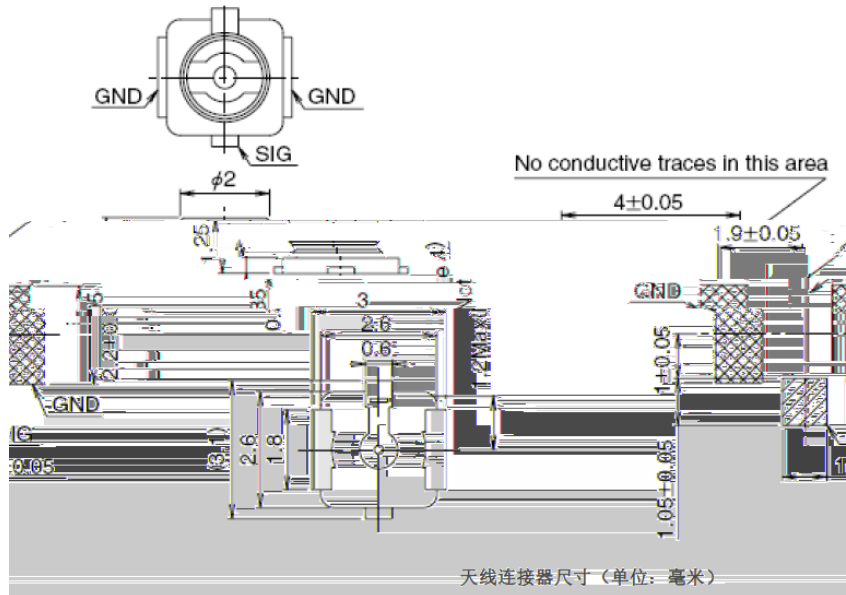

U.FL-LP

	U.FL-LP-022	U.FL-LP-040	U.FL-LP-046	U.FL-LP-068	U.FL-LP-092
Part No.	U.FL-LP-022	U.FL-LP-040	U.FL-LP-046	U.FL-LP-068	U.FL-LP-092
Mated Height	2.4mm Max. (2.3mm Nom.)	2.5mm Max. (2.4mm Nom.)	2.5mm Max. (2.4mm Nom.)	2.0mm Max. (1.9mm Nom.)	2.4mm Max. (2.3mm Nom.)
Coaxial cable	Coaxial cable	Coaxial cable	Coaxial cable	Coaxial cable	Coaxial cable
Weight (mg)	45.5	71.7	53.7	59.1	34.8
RoHS					YES

U.FL-LP 连接线系列

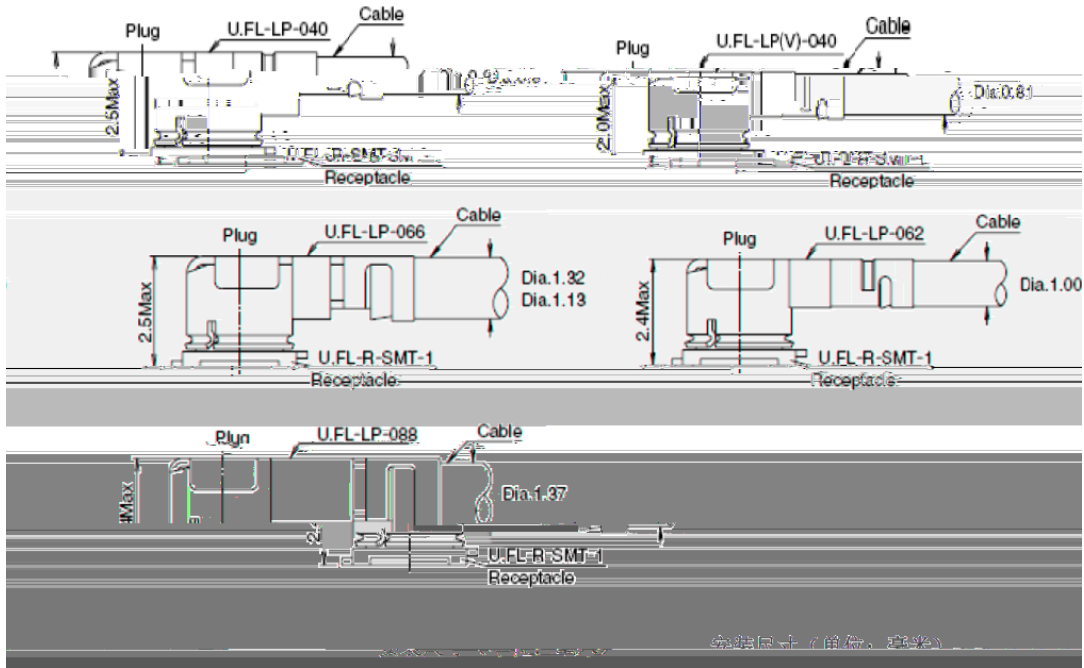

IPEX

<https://www.i-pex.com>

7

7.1

11

TypeC	-0.3	6	V
DC	-0.3	16	V
3.3V	-0.3	3.4	V
	-0.3	3.4	V
ADC0	-	1.2	V
ADC1	-	1.2	V
5V	-	2	A

7.2

12

TypeC		4.5	5.0	5.25	V
DC		4.5	12	16	V
I	LTE	-	1.5	2	A

7.3

13 ESD

642.1 0.47998 23.4 -US642..18 54.54 2.22 reeLang g[642..18 54.54 2.2

5V GND	8	10	KV	
USB	8	10	KV	

8.2

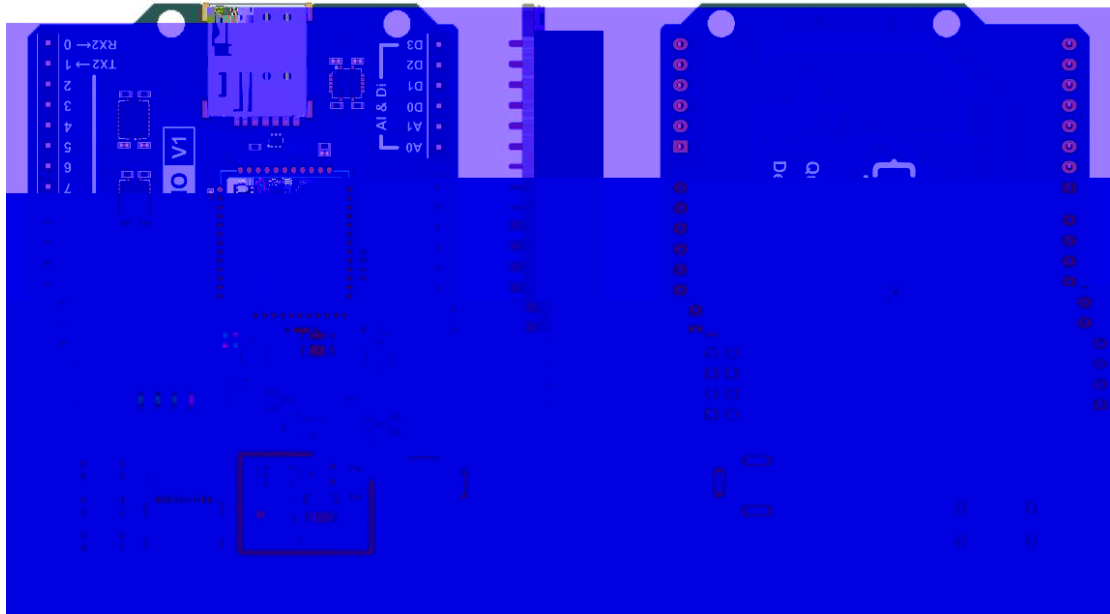

9

- 1
- 2

10 EVB

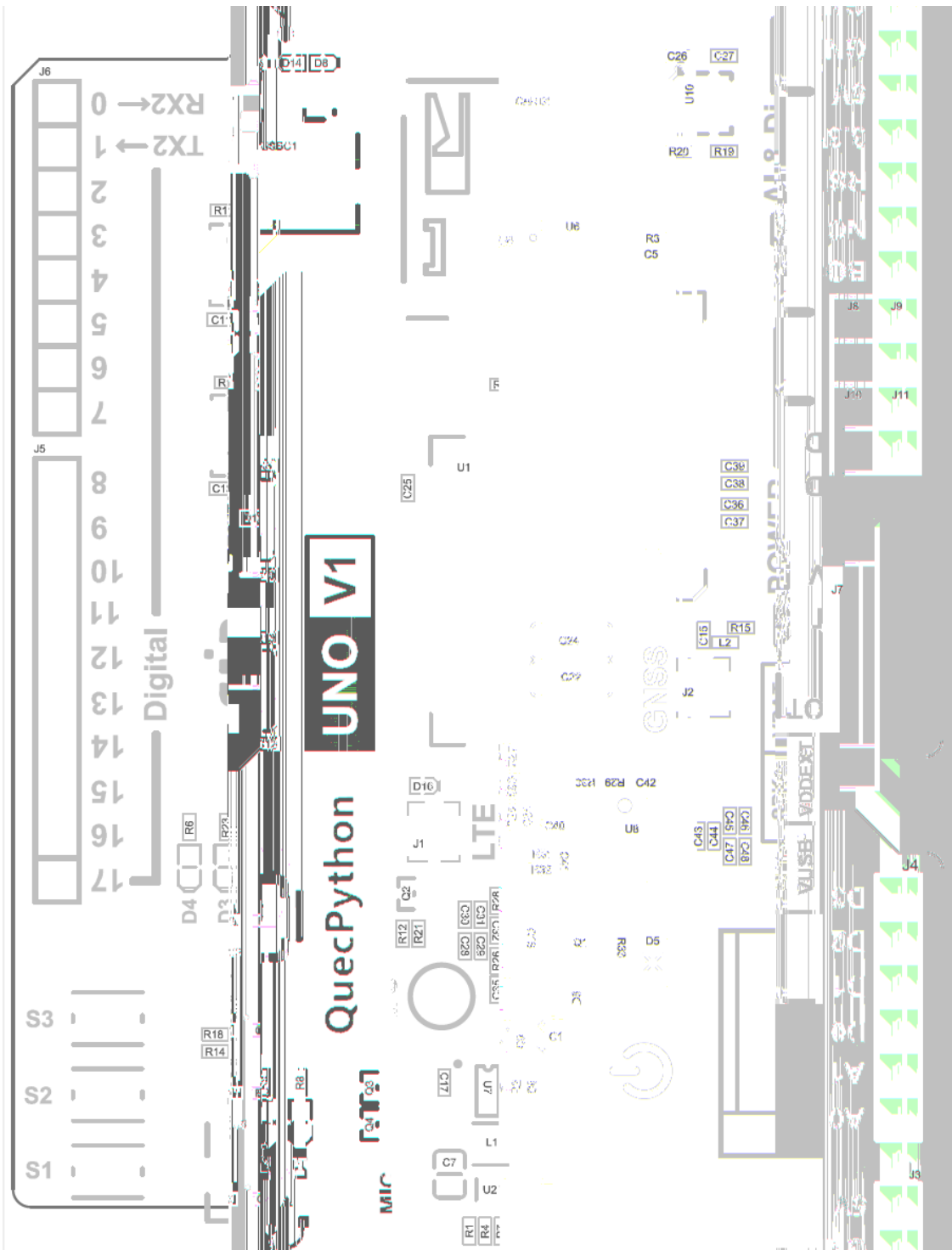

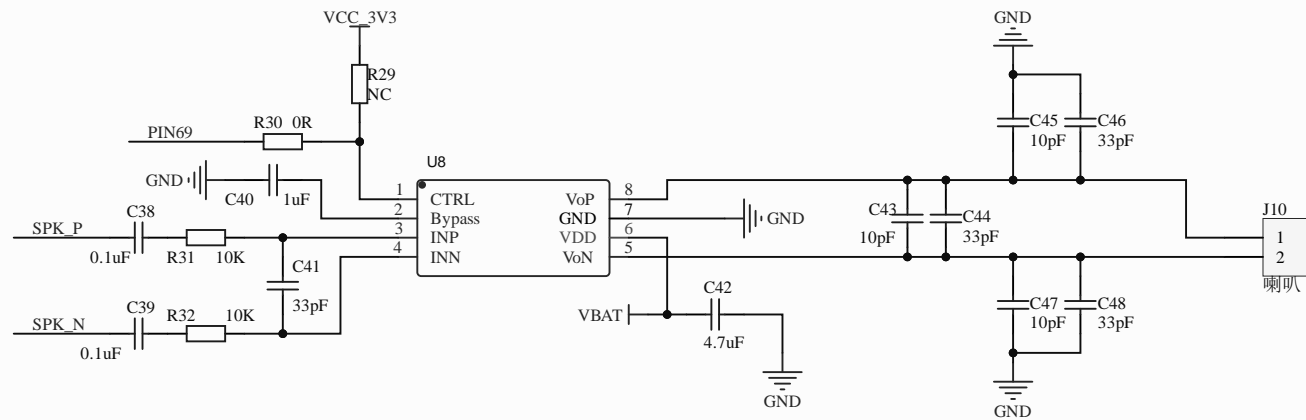
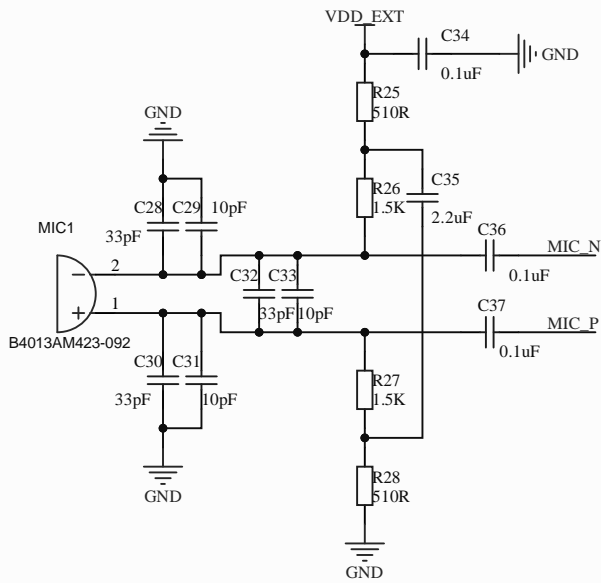

AUDIO

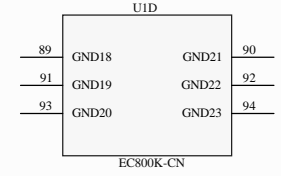
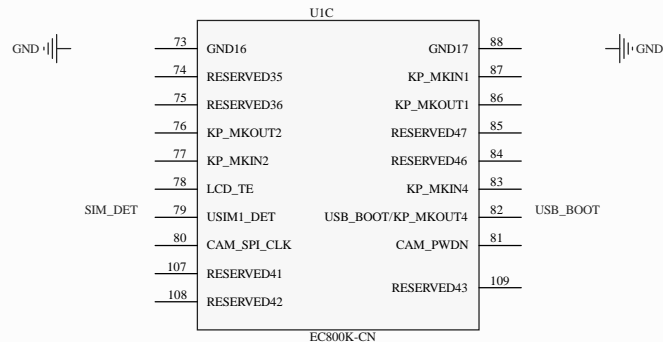
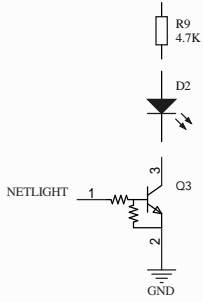
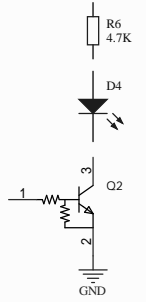
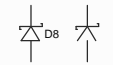
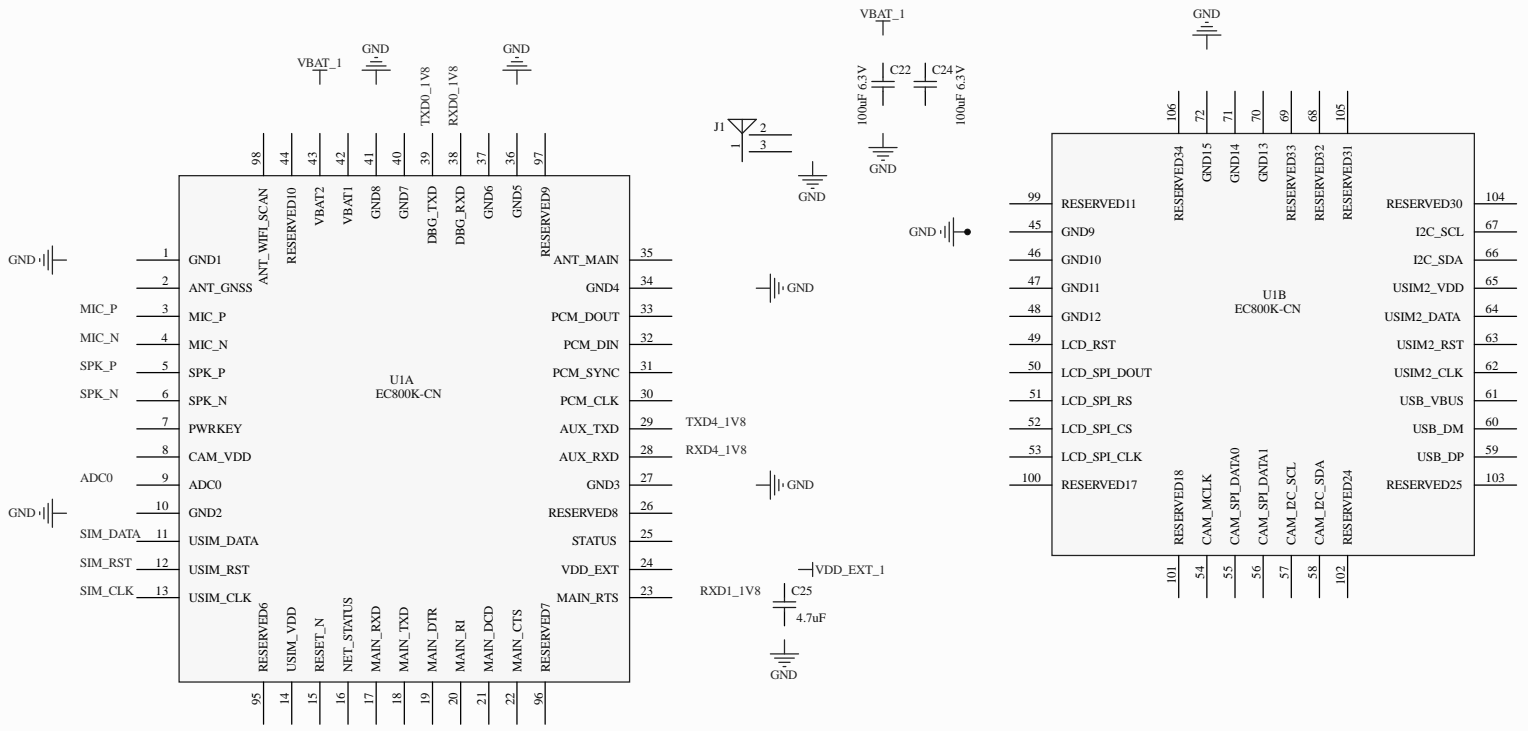

USBC

LED

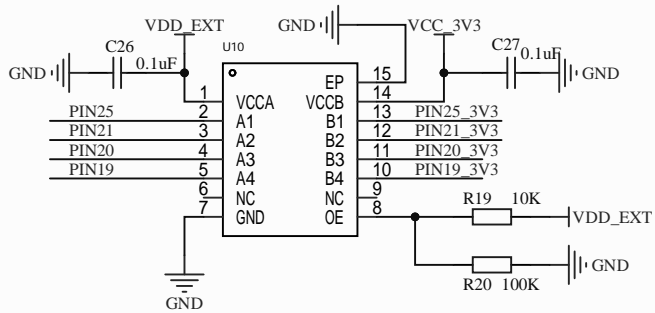
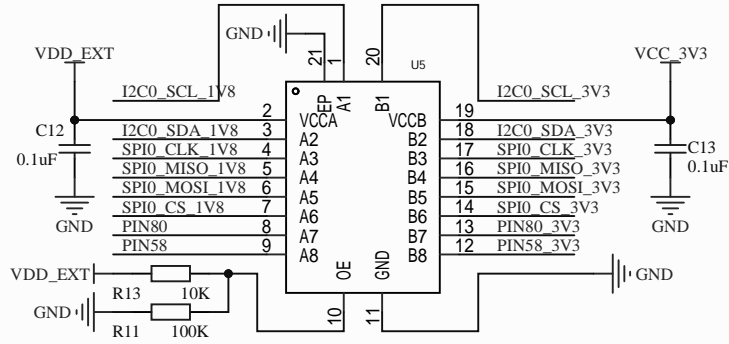
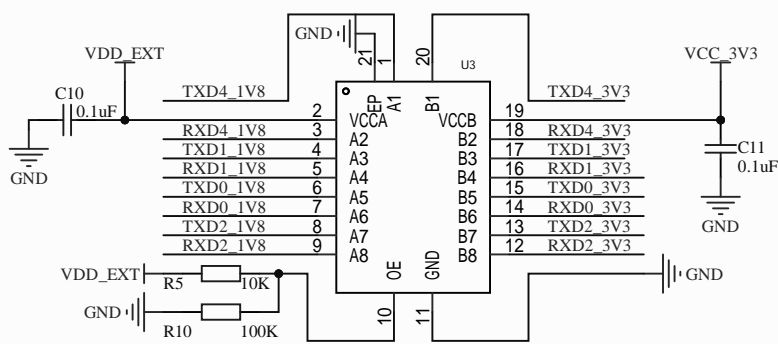

电平转换

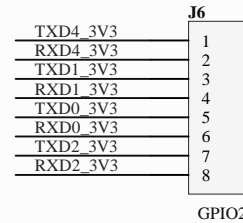
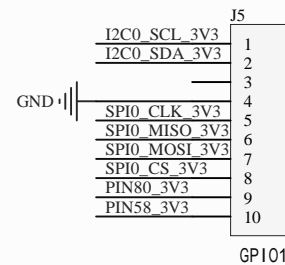
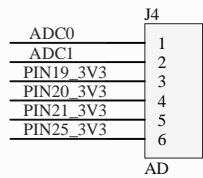
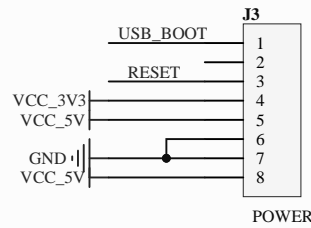

按键和排母

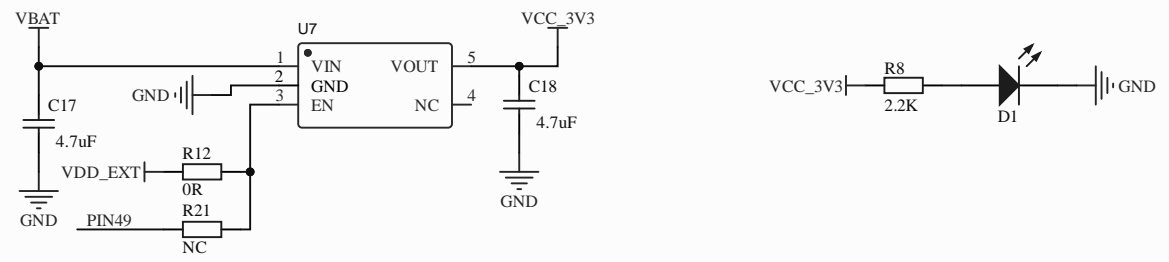

LDO

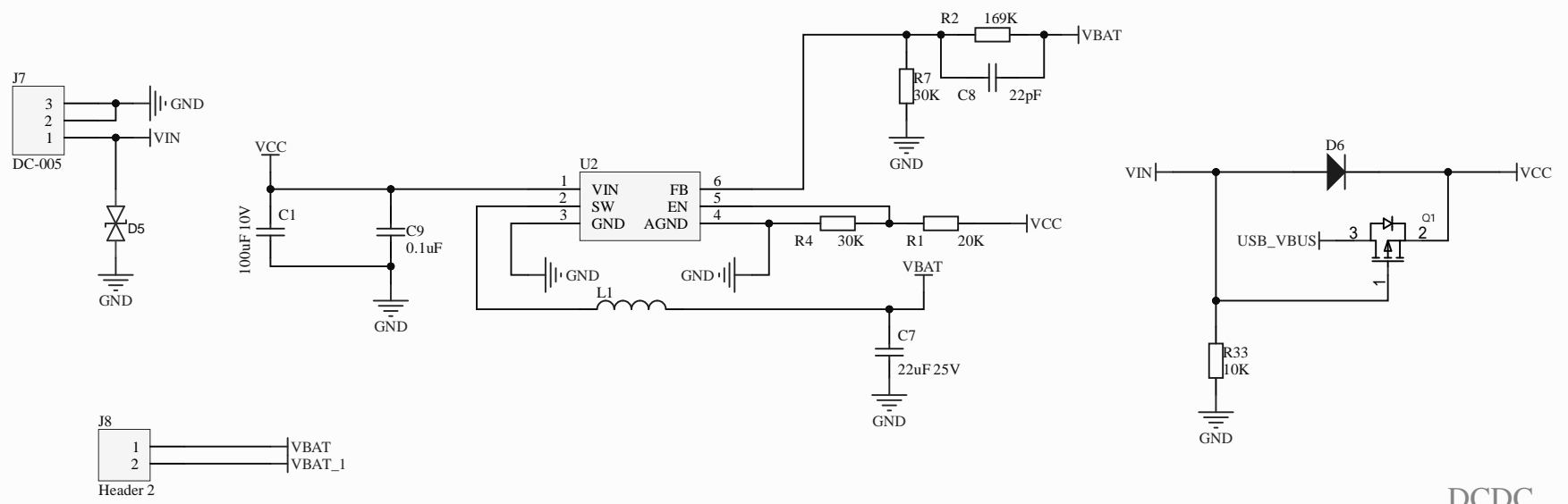

DCDC

1

2

3

4

5

6

A

A

B

B

C

C

D

D

SIM_VDD
 SIM_RST
 SIM_CLK
 SIM_DATA

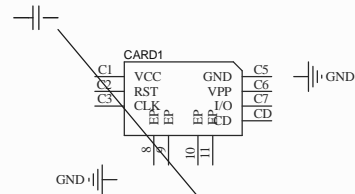
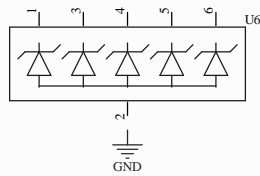

USIM

1

2

3

4

5

6